

EASY SAMPLING

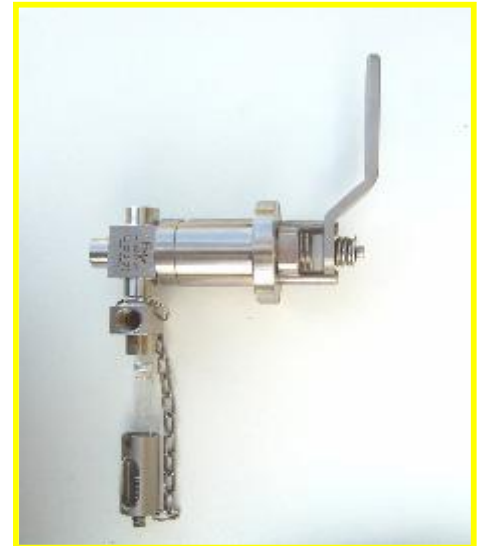

CLOSED LOOP PROCESS SAMPLE VALVES MODEL ES-FLLS-002

Safe & Accurate Sampling for Liquids

- ▶ Spring loaded valve helps to protect against over filling.
- ▶ Separate fluid and vent needles for reliable venting of vapors.
- ▶ Simple replacement of needle assembly without disconnecting piping / tubing.
- ▶ Safer for environment and operator.
- ▶ Simple operation and low maintenance.

The **ES-FLLS-002** needle liquid sampler is designed to collect process samples without emissions to the atmosphere or exposure to the operator. The spring loaded valve insures an extra degree of safety. Dead volume is minimized. The fast loop insures representative sample availability at the valve at all times

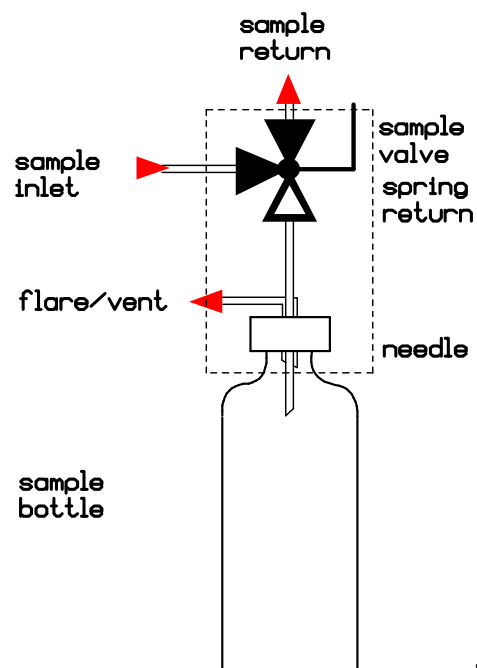

EASY SAMPLING

Sampler Model ES-FLLS-002 " 2 cc."

Customer Interface connection	:	1/4 " NPTF. (1/4" od. And 6 mm.od available)
Valve Material	:	SS-316 / Viton / Teflon.
Pressure	:	750 PSIG / 52 BAR
Temperature	:	38 ° C. / 100 ° F

Other Options Available.

Valve may be floor standing / pipe mounting / enclosure for containment
Consult your Authorized Sales Representative

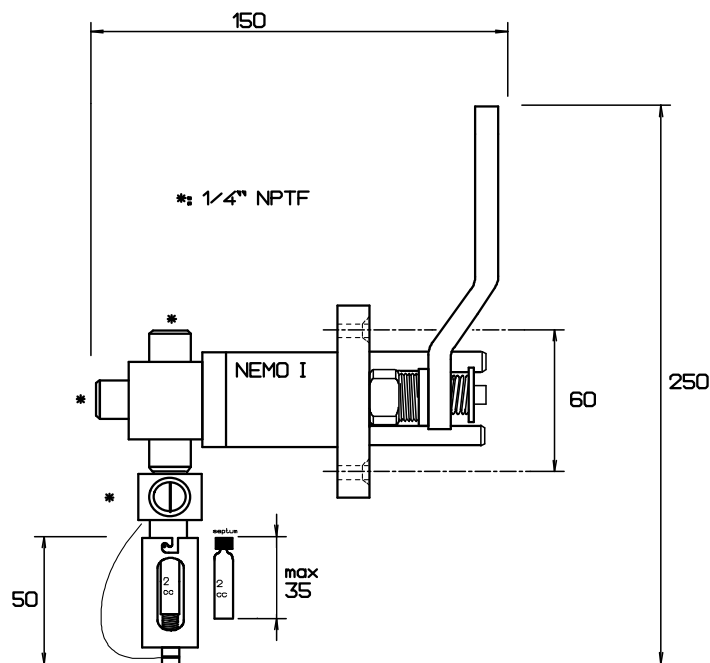

For Further information, contact :

